

# advantage



## 4 piston radial mount B-type caliper - 28mm disc

### PRODUCT REF

CRB304/28-41/44LL

CRB304/28-41/44RL

CRB304/28-41/44LT

CRB304/28-41/44RT

### KEY FEATURES AND BENEFITS

- **Radial mounting for maximum rigidity**  
Firm, consistent pedal
- **Made from aerospace grade aluminium alloy**  
High strength to weight ratio
- **Differential piston diameters**  
Minimises pad taper wear
- **Uses popular B-type pad shape**  
Wide range of friction materials available
- **Pad retaining sleeve**  
High rigidity with straightforward pad changes

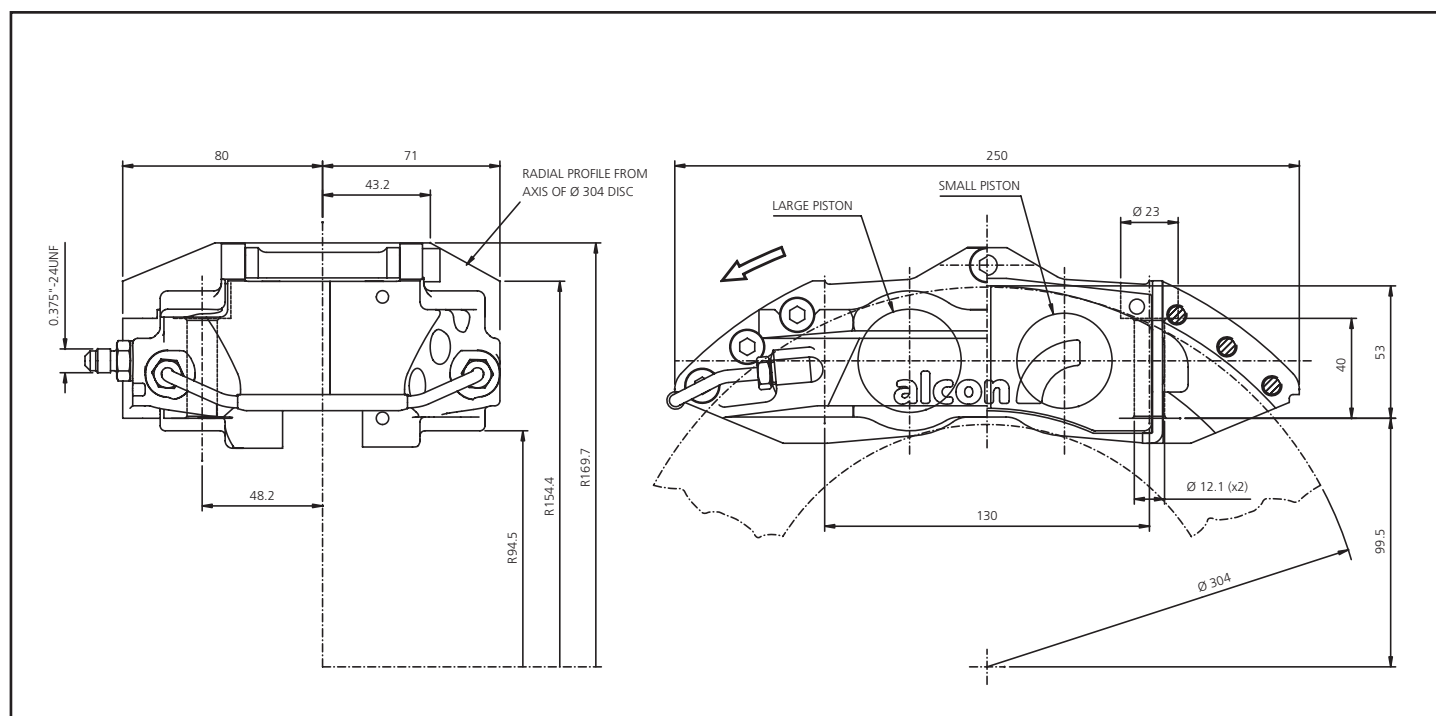
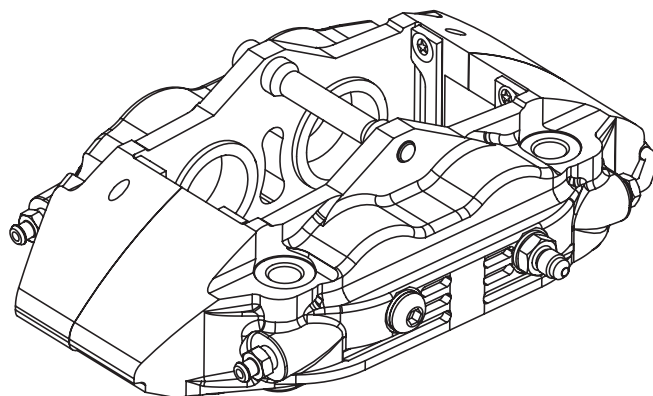

SPECIFICATION	
piston diameter	41.3 / 44.5
disc diameter	250-304
disc thickness	25.4-28
caliper weight	2.56kg
pad area	133 cm <sup>2</sup>
pad thickness	16
seal kit reference	CSK4145E751

PAD SHAPES	
Alcon	4441
Carbone Lorraine	5005W50
Ferodo	FRP1077
Hawk	HB105
Mintex	MDB1697
Pagid	U1595
SBS	3002