

advantage



4 piston radial mount B-type caliper - 32mm disc

PRODUCT REF

CRB330/32-38/41LL

CRB330/32-38/41RL

CRB330/32-38/41LT

CRB330/32-38/41RT

KEY FEATURES AND BENEFITS

- **Radial mounting for maximum rigidity**
Firm, consistent pedal
- **Made from aerospace grade aluminium alloy**
High strength to weight ratio
- **Differential piston diameters**
Minimises pad taper wear
- **Uses popular B-type pad shape**
Wide range of friction materials available
- **Pad retaining sleeve**
High rigidity with straightforward pad changes

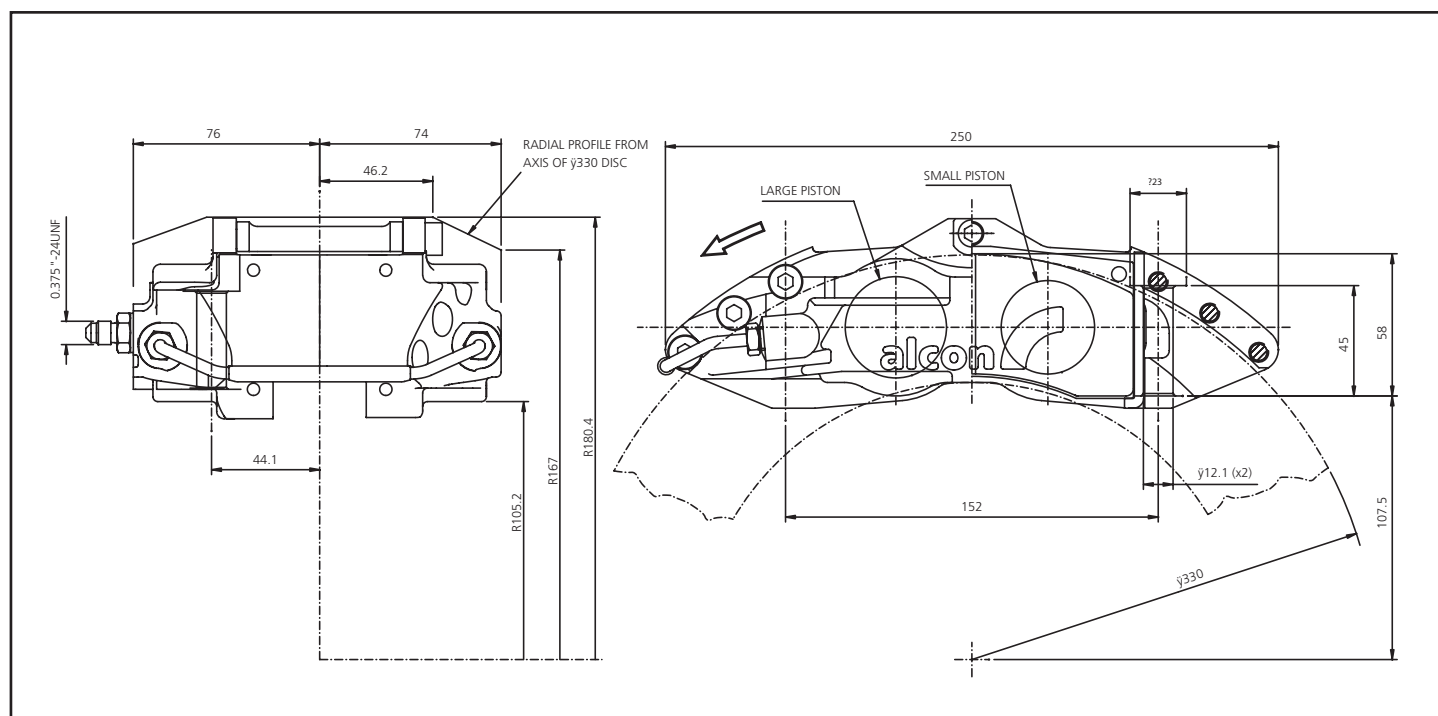
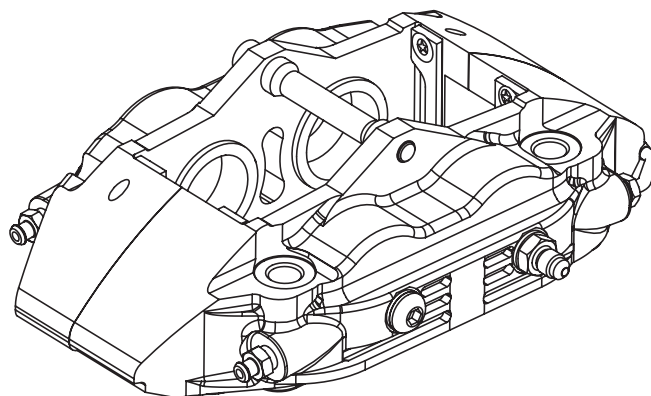

SPECIFICATION

piston diameter	38.1 / 41.3
disc diameter	300-330
disc thickness	28-32
caliper weight	2.70kg
pad area	133 cm ²
pad thickness	16
seal kit reference	CSK3841E751

PAD SHAPES

Alcon	4441
Carbone Lorraine	5005W50
Ferodo	FRP1077
Hawk	HB105
Mintex	MDB1697
Pagid	U1595
SBS	3002