

4 piston radial mount K-type caliper

PRODUCT REF

CRK355/32-41/44LL

CRK355/32-41/44RL

CRK355/32-41/44LT

CRK355/32-41/44RT

KEY FEATURES AND BENEFITS

- **Radial mounting for maximum rigidity**
Firm, consistent pedal
- **Made from aerospace grade aluminium alloy**
High strength to weight ratio
- **Differential piston diameters**
Minimises pad taper wear
- **Uses either popular B-type or K-type pad shapes**
Wide range of friction materials available
- **Pad retaining sleeve**
High rigidity with straightforward pad changes

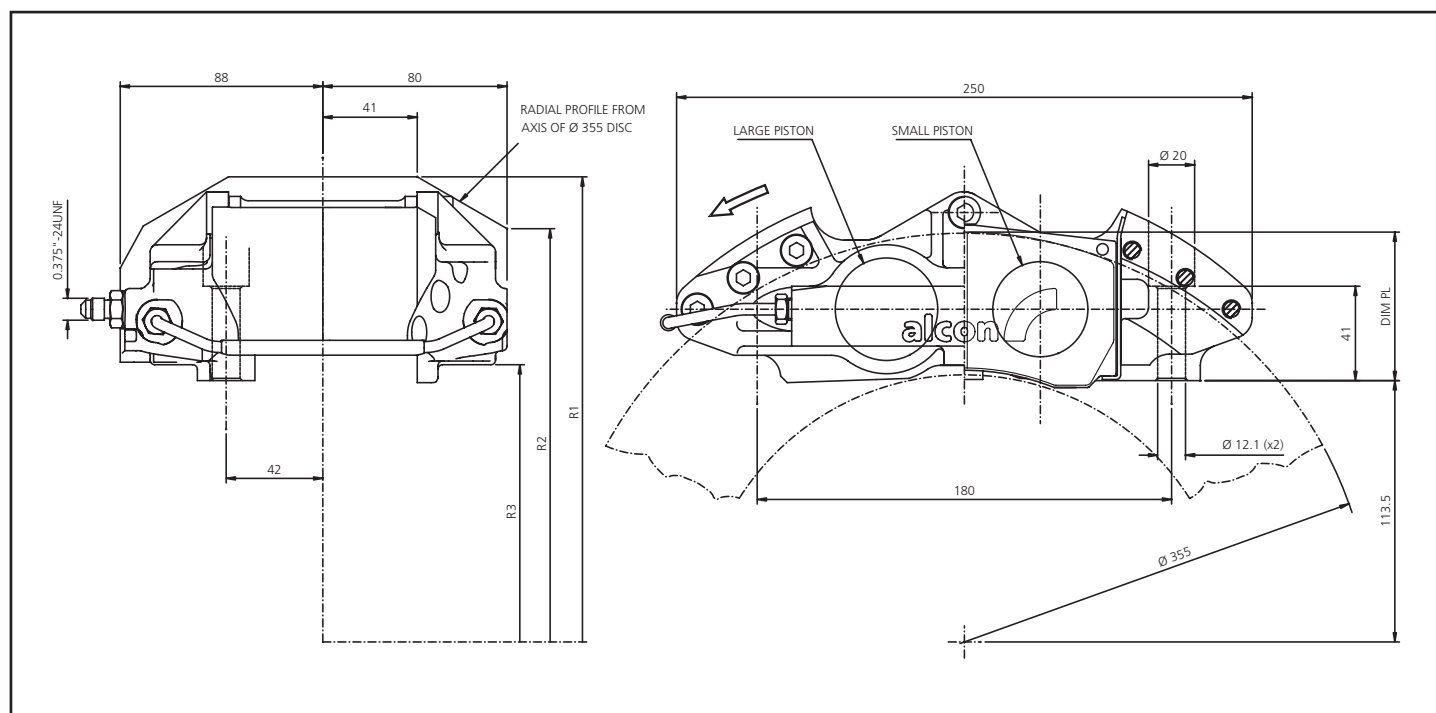
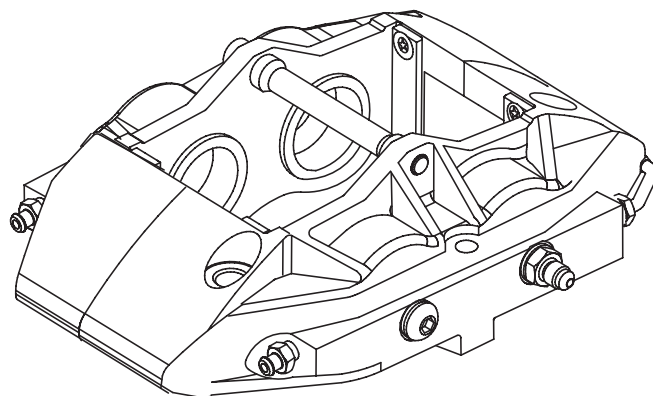

SPECIFICATION

piston diameter	41.3 / 44.5
disc diameter	295-355
disc thickness	28-32
caliper weight	2.7kg
pad area	133 / 152 cm ²
pad thickness	20
seal kit reference	CSK4145E751

PAD SHAPES

Alcon	4476
Ferodo	FRP3012
Hawk	HB187
Pagid	U1756

PAD DETAILS

	DIM PL	R1	R2	R3
B-TYPE	61	202	177	124.0
K-TYPE	64.5	200	175	121.0