

multi-plate race clutch assembly 184mm / 7.25"

KEY FEATURES AND BENEFITS

- **Compact design**
Low weight and moment of inertia
- **High stiffness cover design**
Improved startline control
- **Optimised fulcrum position**
Reduced pressure plate distortion
- **Interchangeability with other manufacturers' clutches**
- **Open lug type design**
Improved cooling & dust removal
- **Interchangeability with other manufacturers' plates**

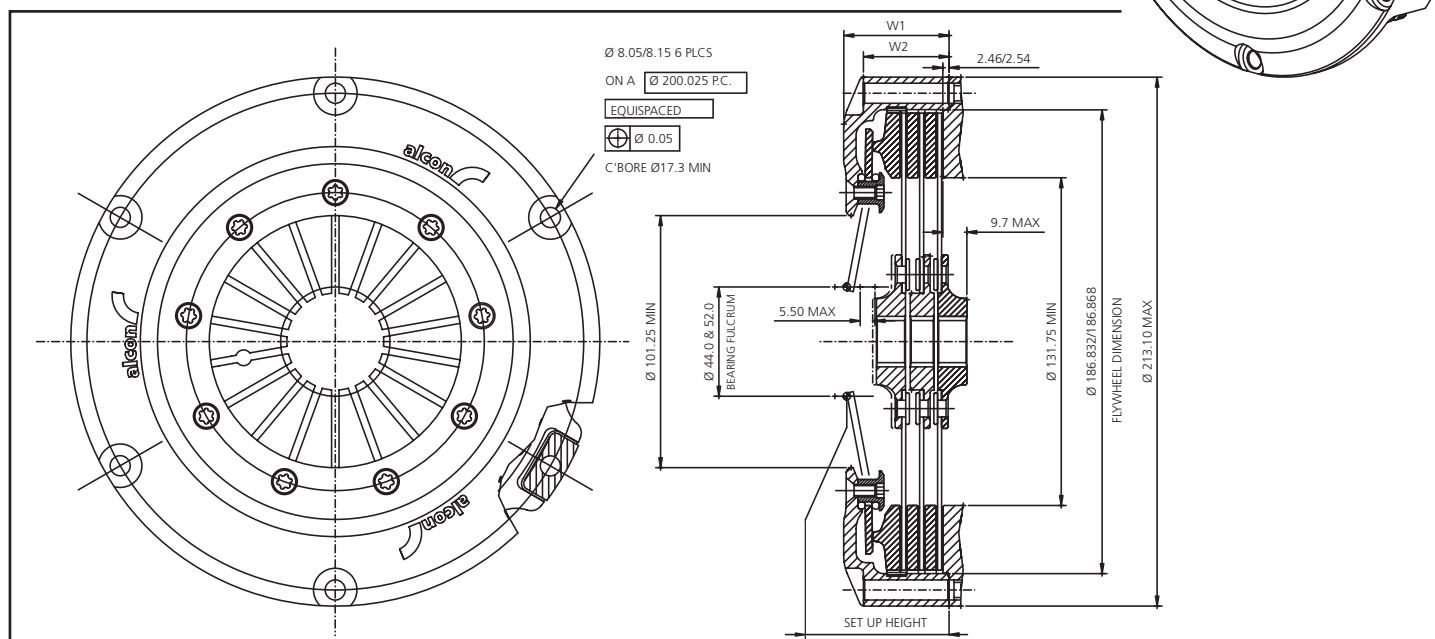
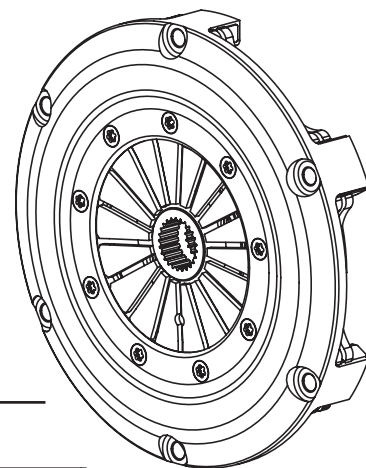

FLOATER PLATE
PRODUCT REF
KPS184L6F180

PRODUCT REF	RATIO	DIM H	D1
KPS184L6H444	High	11.3	157
KPS184L6U444	Ultra high	11.3	152

PRESSURE PLATE DIMENSIONS
Please refer to page 16 for a drawing showing the position of the DIM H and D1 references shown in the table to the left

PRODUCT REF	Ø	PLATES	MAX	SPRING	W1	W2	SET UP HEIGHT	
			TORQUE				RATE	NEW MIN
KKS1841HSGSR01	184	1	305	Grey	27.9	19.7	21	26.2
KKS1842HORSR01	184	2	522	Orange	35.2	27	32.6	38.2
KKS1842HSGSR01	184	2	610	Grey	35.2	27	32.6	38.2
KKS1842HDGSR01	184	2	678	Double grey	35.2	27	32.6	38.2
KKS1843HDGSR01	184	3	1002	Double grey	42.4	34.3	35.5	39.5
KKS1843UDGSR01	184	3	1320	Double grey	42.4	34.3	35.5	39.5