

race drive plates

140mm / 5.50"

KEY FEATURES AND BENEFITS

- **Optimised hub length**
Low inertia with minimum input shaft wear
- **Sintered material**
High energy capacity
- **High strength spring steel core plate**
- **Interchangeability with other manufacturers' plates**

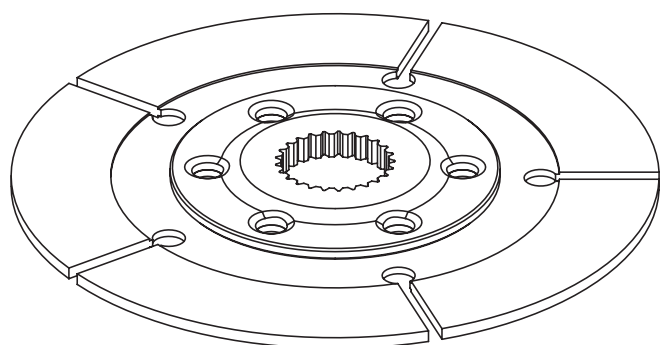

PRODUCT REF						
SPLINE SIZE			140MM Ø			
NOMINAL	Ø	TEETH	A-TYPE	B-TYPE	C-TYPE	
21 x 18	21.1	18	KDS550FA17X001	KDS550FB17X001	-	
22 x 26	22.0	26	KDS550FA35X001	KDS550FB35X001	-	
7/8" x 20	22.2	20	KDS550FA25X001	KDS550FB25X001	KDS550FC25X001	
24.25 x 21	24.3	21	KDS550FA27X001	KDS550FB27X001	KDS550FC27X001	
1" x 23	25.4	23	KDS550FA30X001	KDS550FB30X001	KDS550FC30X001	
1" x 24	25.4	24	KDS550FA33X001	KDS550FB33X001	-	
1 1/16" x 10	27.0	10	KDS550FA05X001	KDS550FB05X001	-	
1 5/32" x 26	29.5	26	KDS550FA36X001	KDS550FB36X001	-	
1 1/4" x 10	31.8	10	KDS550FA07X001	KDS550FB07X001	-	

B-type plates can be used on the flywheel side of the unit to provide increased hub to crank bolt clearance

C-type plates to be used as middle plates in triple or 4 plates clutch assemblies