

twin plate rally clutch assembly 140mm / 5.50"

KEY FEATURES AND BENEFITS

- **Compact design**
Low weight and moment of inertia
- **High stiffness cover design**
Improved startline control
- **Optimised fulcrum position**
Reduced pressure plate distortion
- **Open lug type design**
Improved cooling and dust removal
- **Interchangeability with other manufacturers' products**

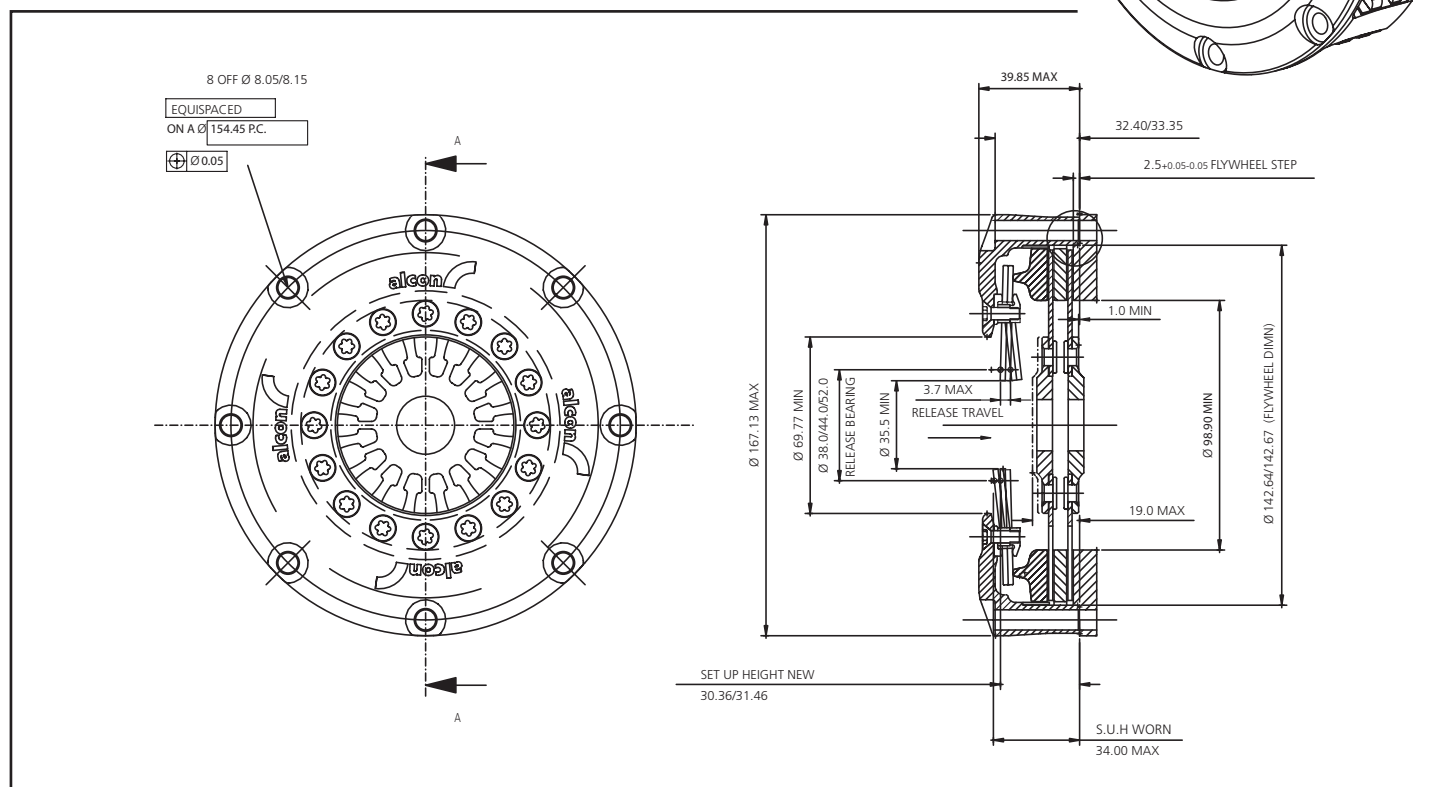
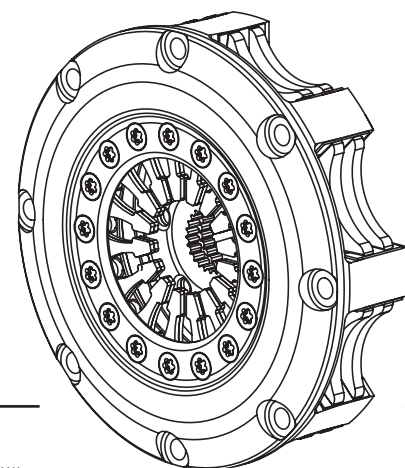

PRODUCT REF	MAX TORQUE	SPRING RATE
KKR1402HDGSR01	572NM	Double grey
KKR1402HORSR01	472NM	Orange

For pot type flywheels replace SR in the part number with PR to obtain new clutch part number

FLOATER PLATE
PRODUCT REF
KPS140L08FX01

PRESSURE PLATE			
PRODUCT REF	RATIO	DIM H	D1
KPS140L08H450	High	11.5	117
KPS140L08U450	Ultra high	11.5	114

